



RECOMMENDATIONS FOR WHEEL END LUBRICATION

PREFACE

The following Recommended Practice is subject to the Disclaimer at the front of TMC's *Recommended Maintenance Practices Manual*. Users are urged to read the Disclaimer before considering adoption of any portion of this Recommended Practice.

PURPOSE AND SCOPE

The purpose of this Recommended Practice (RP) is to offer equipment users recommendations and operational considerations for selecting, inspecting and using lubricants in wheel end applications.

This Recommended Practice (RP) applies to Class 3-8 trucks, buses, tractors, and trailers designed for on-highway applications. This RP applies to only "traditionally" equipped axles and hubs, and excludes unitized hubs.

For pre-adjusted and unitized wheel hubs refer to RP 640B, *Alternate Wheel Bearing Adjustment Systems*. For additional information on lubricants, wheel bearing adjustment, installation and maintenance, refer to TMC:

- RP 618A, *Wheel Bearing Adjustment Procedures*
- RP 622A, *Wheel Seal and Bearing Removal, Installation, and Maintenance*
- RP 624A, *Lubricant Fundamentals*
- RP 640B, *Alternate Wheel Bearing Adjustment Systems*
- RP 644A, *Wheel End Conditions Analysis Guide*

Fleet managers should also reference original equipment manufacturer (OEM) maintenance and service manuals as appropriate.

INTRODUCTION

Two categories of wheel ends are addressed: driven and non-driven. Non-driven wheel ends include steer, dolly, trailer, pusher and tag axles. (See **Figures 1 and 2**). The lubricant used in the wheel ends can be either **petroleum-based** or **synthetic-based** oils or greases.

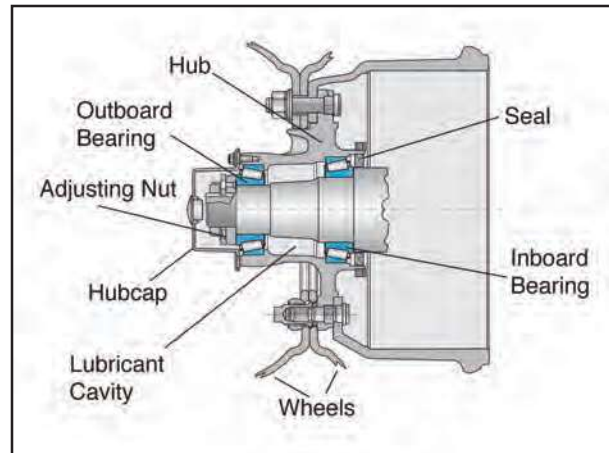

Fig. 1: Non-Drive Wheel End

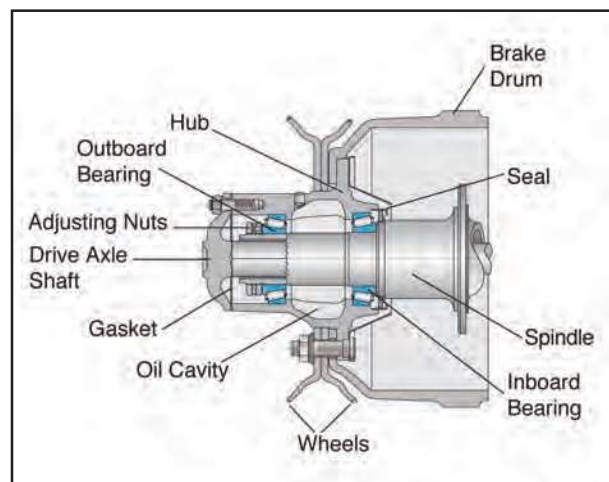

Fig. 2: Drive Axle Wheel End

LUBRICANT CONSIDERATIONS

Non-driven wheel ends can be lubricated effectively with either oil or grease, depending on the fleet preference. Both lubricating substances use oil as the lubricating medium. (Refer to RP 624A, *Lubricant Fundamentals* for details.)

Drive axle wheel ends, however, can be lubricated effectively only with oil.

Section A: General Guidelines features procedures that apply to all types of wheel ends.

Sections B through D offer recommendations specific to a given application as follows:

- Section B: Non-Driven Wheel End, Oil Lubricated
- Section C: Non-Driven Wheel End, Grease Lubricated
- Section D: Drive Axle Wheel End

Section A: General Guidelines

Inspection and Preparation

Clean and inspect the wheel end components including all bearings, hubcaps, hub and bearing cups, axle spindle, axle shaft (drive axle only), and fasteners, removing all contaminants and lubricant residue. Replace seal, hubcap gasket, and all questionable parts. For detailed procedures, refer to TMC RP 622A. For failure analysis, see TMC RP 644.

Component Lubrication

Pre-lubricate the inner and outer wheel bearing cones with clean lubricant of the same type used in the hub assembly. This will help inhibit fretting corrosion and make assembly easier. Install the wheel seals as documented in TMC RP 622A.

CAUTION: Failure to lubricate bearings correctly, and maintain the proper lubrication level, may result in premature bearing damage. For additional information refer to TMC RP 618A and RP 622A.

CAUTION: In oil bath systems, do not pack bearings with grease before installation. Grease will temporarily restrict or prevent the proper circulation of lubricating oil and may contribute to wheel seal failure.

Use lifting equipment to align the hub assembly with the spindle taking care not to damage the seal and spindle threads.

Install the outer bearing, and adjusting nut systems. Adjust wheel bearings using TMC RP 618A. Verify end play (0.001" to 0.005") with a dial indicator.

NOTE: On pre-adjusted wheel end systems refer to the OEM or supplier maintenance manual or installation instructions. Then verify end play with a dial indicator.

Section B: Non-Driven Wheel End, Oil Lubricated

Hub Fill Procedures: Oil

While the hub is supported/suspended, fill the hub cavity with clean lubricant and push the hub into position, or push the hub into position and then fill the hub cavity. In either case add lubricant to the hub cavity.

Hubcap Considerations: Oil

Select the proper vented, bolt-on or threaded hubcap for the application and follow hubcap suppliers' instructions for proper attachment to the wheel hub. Fill wheel end assembly through the fill port with the same oil. Allow time for the oil to seep through the outer bearing and re-fill the hub cavity. Continue to add oil until the oil reaches the oil full line as indicated on the hubcap. (See **Figure 3**.)

NOTE: For hubcaps with side fill plugs, do not allow the lubricant to go past the centerline or vent hole.

Install center fill or side fill plug. Torque side fill plug to recommended tightness. Wipe away any over spills that would give the appearance of a leaking hubcap.

Section C: Non-Driven Wheel End, Grease Lubricated

NOTE: Semi-fluid greases are NLGI 000 and 00. NLGI 0 is a soft grease as described in RP 624A, *Lubricant Fundamentals*. All three grades listed above are treated as semi-fluid greases in this RP.

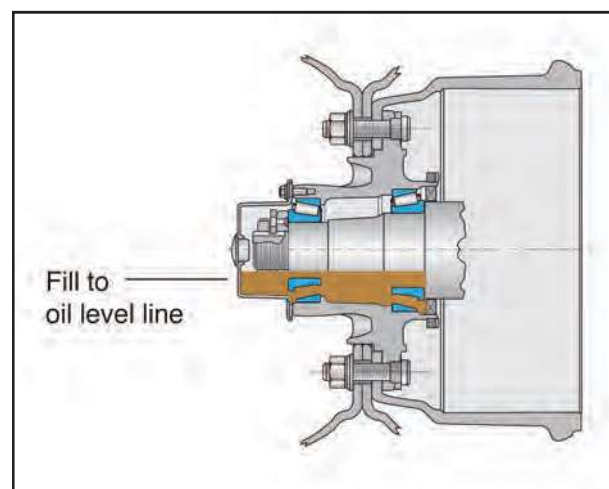

Fig. 3: Lubrication Fill—Oil (Static)

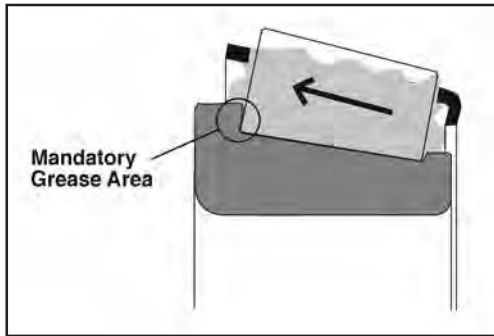

Fig. 4: Packing of Bearing Cone

Hard greases are defined as NLGI 1, 2, and 3 consistencies in this RP.

NOTE: If retrofitting an oil or grease system with a semi-fluid grease, be sure to note the need for special cleaning instructions, fill procedures and equipment (i.e., vented or non-vented hubcap).

Pack the inner and outer wheel bearing cones full with grease. Work the grease into the bearing in the direction of the arrow shown in **Figure 4** by machine or hand such that the grease goes under the bearing cage toward the cone rib and roller ends

For corrosion prevention, place a light film of grease on all metal components, including the hubcap. Wipe off the excess grease. Install the bearings and wheel seals as described in TMC RP 622A.

CAUTION: If grease packing is done by hand, appropriate protection — such as gloves and clothing — should be worn to minimize skin contact with the grease.

NOTE: If a metal hub cap is used, it is necessary to coat the interior surfaces with a film of grease. Use special care not to cover the vent (if vented) with grease.

Before installing the hubcap, apply a coating of grease around the wheel bearing fasteners (adjusting nut(s)).

Hub Fill Procedures: Semi-fluid Grease

If tires are not mounted, install the hub on the spindle. Take care to not damage the seal. Push the hub assembly into position. With the hub supported, before installing the outer bearing cone, begin filling from the bottom of the hub cavity. Top-off by placing the pump nozzle above the spindle, and continue pumping grease into the hub cavity. (See **Figure**



Fig. 5: Semi-Fluid Grease Top-off Procedure

5.) The grease fill amount should be to a 3 o'clock and 9 o'clock level. This represents 50 percent hub cavity fill. (See **Figures 5A and 5B.**)

NOTE: A template may be used to hold the lubricant in place while filling the hub cavity. (See **Figures 5 and 5C.**)

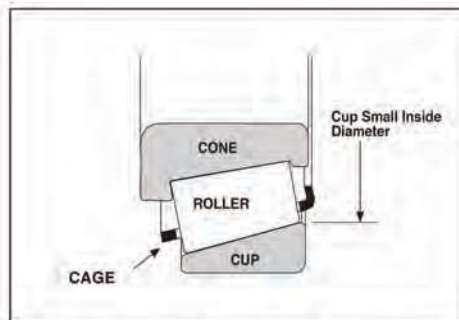

Fig. 5B: Tapered Bearing Nomenclature

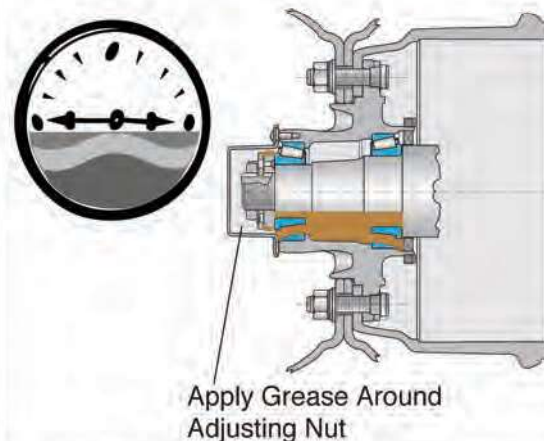

Fig 5A: Lubrication Fill Semi-Fluid Grease (No. 00)



Fig. 5C: Using Template to Hold Lubricant

⚠ CAUTION: Make sure that there are no air-pockets trapped under the grease. If pumping equipment is used, ensure the pump does not aerate the grease. Aeration of the grease may result in under-filling.

Hub Fill Procedures: Hard Grease

Before installing the hub, pack grease into the hub cavity. Fill the circumference of the hub cavity using the bearing races as the proper level guide. (See **Figure 6**.) Push the hub assembly into position. Install the outer bearing, washers and adjusting nuts.

Hubcap Considerations:

Semi-Fluid Grease & Hard Grease

Use an appropriate tamper-proof, vented hubcap. These hubcaps prevent gear oils from being accidentally added to grease-filled wheel ends.

- **Semi-fluid Grease**— Because of the hubcap's special venting capability and the properties of the semi-fluid grease, do not fill the hubcap with grease.
- **Hard Grease**— Follow the recommendation of the seal supplier to determine if the hubcap should be vented or non-vented.

Section D: Drive Axle Wheel End

NOTE: All driven axles are oil lubricated.

Hub Fill Procedures: Oil

Push the hub assembly into position. While the hub is supported, fill the hub cavity with clean oil and push into position or push into position and then fill the hub cavity.

Install the outer bearing, making sure that cups and cones are properly matched. Install the washers and adjusting nut(s).

Install the flanged drive axle shaft with a new axle flange gasket. Torque flange nuts to axle manufac-

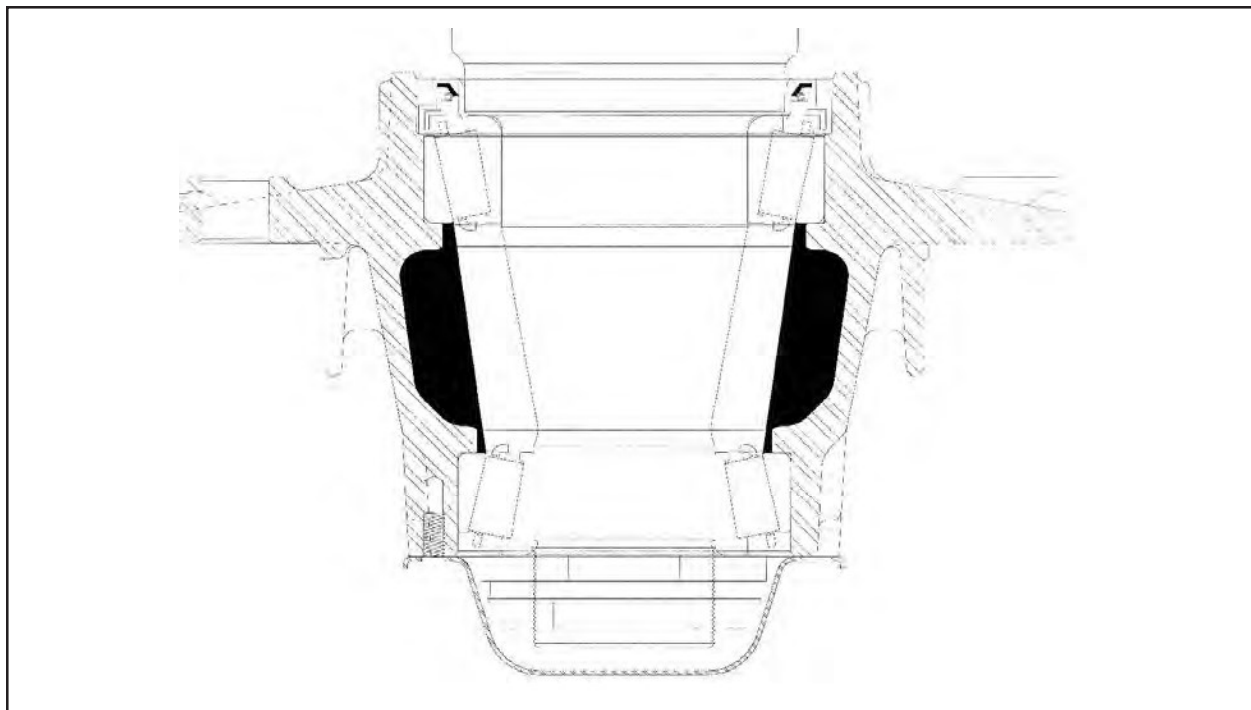

Fig. 6: Lubrication Fill Greases (Nos. 1, 2 & 3)

turer's specification. Clean-up any over spills that would give the appearance of a leaking system. Oil is supplied directly to the wheel ends at assembly and through the axle tube during operation.

To achieve final fill level, each end of the drive axle must be raised a minimum of eight inches for one minute to move the lubricant into the opposite wheel end. Recheck the main sump for the proper oil level and top off the lubricant level, if required. The proper oil fill level is always level with the bottom of the fill plug hole in the axle reservoir.

There is no hubcap on drive axles. The end of the axle is sealed by the axle flange and axle flange gasket.

NOTE: Always check the axle breather to be sure it is operating properly and completely free of dirt and debris.

MAINTENANCE AND INSPECTION REQUIREMENTS

The following inspection criteria are intended for units whose vocation is strictly on-highway use only. The inspection criteria are not intended for unitized or pre-set wheel ends, refer to systems manufacturer for inspection and service recommendations. These recommendations depend on the proper assembly of the system, including the proper lubricant fill level.

Wheel End Inspection Criteria

Level 1—Simple Inspection (Pre-Trip/In-Service/Post-Trip)

Walk around vehicle and check wheel-ends for obvious signs of lubricant leakage, such as hubcap gaskets and wheel seal areas, and oil soaked brake linings. Check for broken or missing components. Any seepage is reason for further inspection and appropriate action. Go to **Level 4** inspection if leaks or oil soaked brake linings are noted.

NOTE FOR DRIVERS: After making an en route stop, walk around the unit and feel the hubs. If there are any significant differences in temperatures or excessive temperature, contact your maintenance department. When feeling hubs for temperature, seasonal influences should be taken into consideration. If wheel ends are equipped with a sight glass on the hubcaps, check to ensure the oil is at the proper fill level.

NOTE: Oil residue may be present at the vent area. This is an indicator that the system is venting properly.

This should not be construed as system leakage.

 **CAUTION:** A clogged vent can damage the wheel seal allowing internal pressure build up in the wheel end.

Level 2—100,000 miles or Annual Inspection:

Check wheel-ends for obvious signs of lubricant leakage, such as:

- hubcap gasket or axle flange gasket areas
- wheel seal areas
- grease or oil soaked brake linings

Check lubricant level and condition. If lubricant is contaminated replace old lubricant with the same type lubricant. If lubricant condition is good and level is low, fill to the proper level.

NOTE: Leaking grease may not spread over the hub and brake components as with hubs filled with oil. When inspecting for grease leaks the inspection must be done very carefully with the aid of a bright beam of light from a flashlight or droplight.

NOTE: Some grease seals will purge very small amounts of grease in normal operation. If there is seepage around the hubcap flange area, take appropriate action to eliminate seepage as directed by your maintenance instructions. If leakage in the seal area is found, remove the wheel end and replace the hubcap gasket, seal and lubricant. Inspect the spindle and bearings for damage and replace if needed. Go to **Level 4** inspection if leaks or oil soaked brake linings are noted.

Non-driven axles: Raise the vehicle and check for smooth rolling of wheels. Check for signs of excessive end play in the wheel-end. This does not include removal of the hub cap. Go to **Level 4** inspection if leaks or oil soaked brake linings are noted.

Driven axles: Check for leaks at hub fill hole if so equipped. Check the breather for cleanliness, security, and signs of excessive oil leakage.

Level 3—Lube Level Inspection (Per OEM Recommendation)

A Level 3 inspection only applies to a wheel end that is lubricated with a semi-fluid grease. If using a hard grease, there is no need for a Level 3 Inspection. The only method to accurately check the lubricant level is by pulling the outer bearing.

 **CAUTION**: Failure to remove the outer bearing may provide a false lubricant level reading.

To verify proper lubricant level the following procedures need to be performed.

1. Before performing any maintenance on the vehicle take appropriate action to ensure the vehicle is safely secured.
2. Remove hubcap, hubcap gasket and inspect hubcap for adequate venting capabilities.
3. Verify wheel-bearing end play for conformance to RP 618A.
4. Record end play measurements.

 **CAUTION**: Apply the parking brake, if axle is equipped. This will ensure that the wheel/hub assembly is supported and held steady during removal of the spindle nut and outer bearing. This will eliminate the possibility of spindle, bearing or seal damage due to the cocking or slipping of the wheel-hub assembly.

 **CAUTION**: Care should be taken so the wheel-end assembly is properly supported.

5. Remove adjusting nuts.
6. Remove outer bearing.
7. While maintaining proper support to the wheel end or hub, visually check lubricant level. In a semi-fluid grease system, if the lubricant flows out of the hub cavity, the hub cavity should be refilled to the 3 o'clock and 9 o'clock level. This represents 50 percent hub cavity fill. (See **Figures 5 and 5A.**) In a semi-fluid grease system, if the grease doesn't flow, inspect lubricant condition in the hub cavity. Go to **Level 4** Inspection if abnormal conditions are noted. If no abnormal conditions are noted, add grease until it flows out of the hub cavity.

NOTE: If changing grease types or brands, contact your lubricant supplier to insure compatibility.

8. Clean bearing and inspect for wear and damage. When reassembling industry standard wheel ends, assemble per RP 618A. Measure the end play with a dial indicator.

Level 4—Wheel-end Disassembly Inspection (Complete System Tear-down)

1. If any abnormal conditions are found during inspection Levels 1, 2, or 3, remove wheel-end for inspection.

2. Lubricant change intervals as recommended by the manufacturer dictates when Level 4 service is performed.
3. Anytime the lubricant is changed in a wheel end system, the bearings should be removed, cleaned and inspected before returning the unit to service.

NOTE: Manufacturer is defined as the final assembler of the product or the particular system supplier. When reassembling industry standard wheel-ends, assemble per RP 622A and RP 618A, seals and gaskets must be replaced. Always verify the end play with a dial indicator after the proper torque has been applied to the entire fastener system.

FAILED COMPONENT ANALYSIS

Save prematurely failed parts and lubricant samples for inspection and analysis. The lubricant sample collected should be at least four ounces.

NOTE: The sample should be taken in a clean, dry container and promptly covered.

A similarly sized new lubricant sample (not previously used) is also required for proper comparison. This will aid in supplier assisted detection and prevention of premature failures. The components' history of usage should also be provided (e.g., vehicle's vocation, mileage, maintenance records, and history of inspection and repair/replacement of components such as seals, seal wear rings, lubricant, bearings, etc.).

OPERATIONAL CONSIDERATIONS FOR LUBRICANTS

Service interval ranges from 100,000 miles to five years in over-the-road service, depending on axle type, manufacturer recommendations, and lubricant performance capabilities. Mineral oil based lubricants have lower initial costs than synthetics lubricants, but need to be changed more frequently in some equipment. When choosing a lubricant, the fleet needs to consider the following factors:

- manufacturer's recommendation for the axle make and model in service.
- fleet savings associated with extended service intervals.
- total cost of the lubricant.

NOTE: If you are switching lubricants, consult your seal supplier for compatibility concerns. Not all lubricants are compatible with all seal materials.